

**CROWN**

**FC 4000 Series**  
sit-down rider lift truck

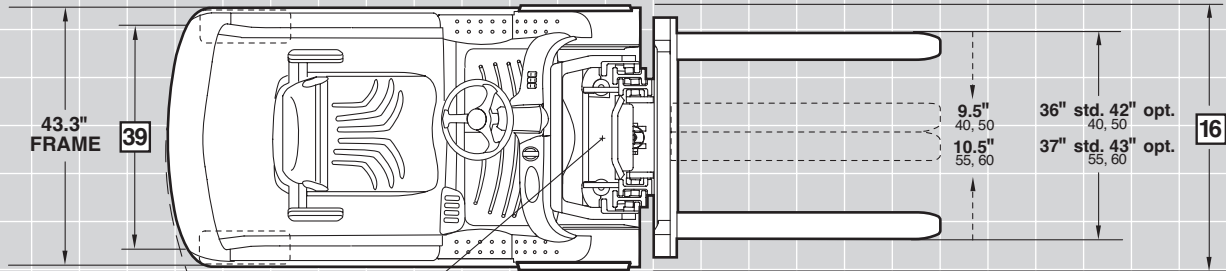

specifications



21

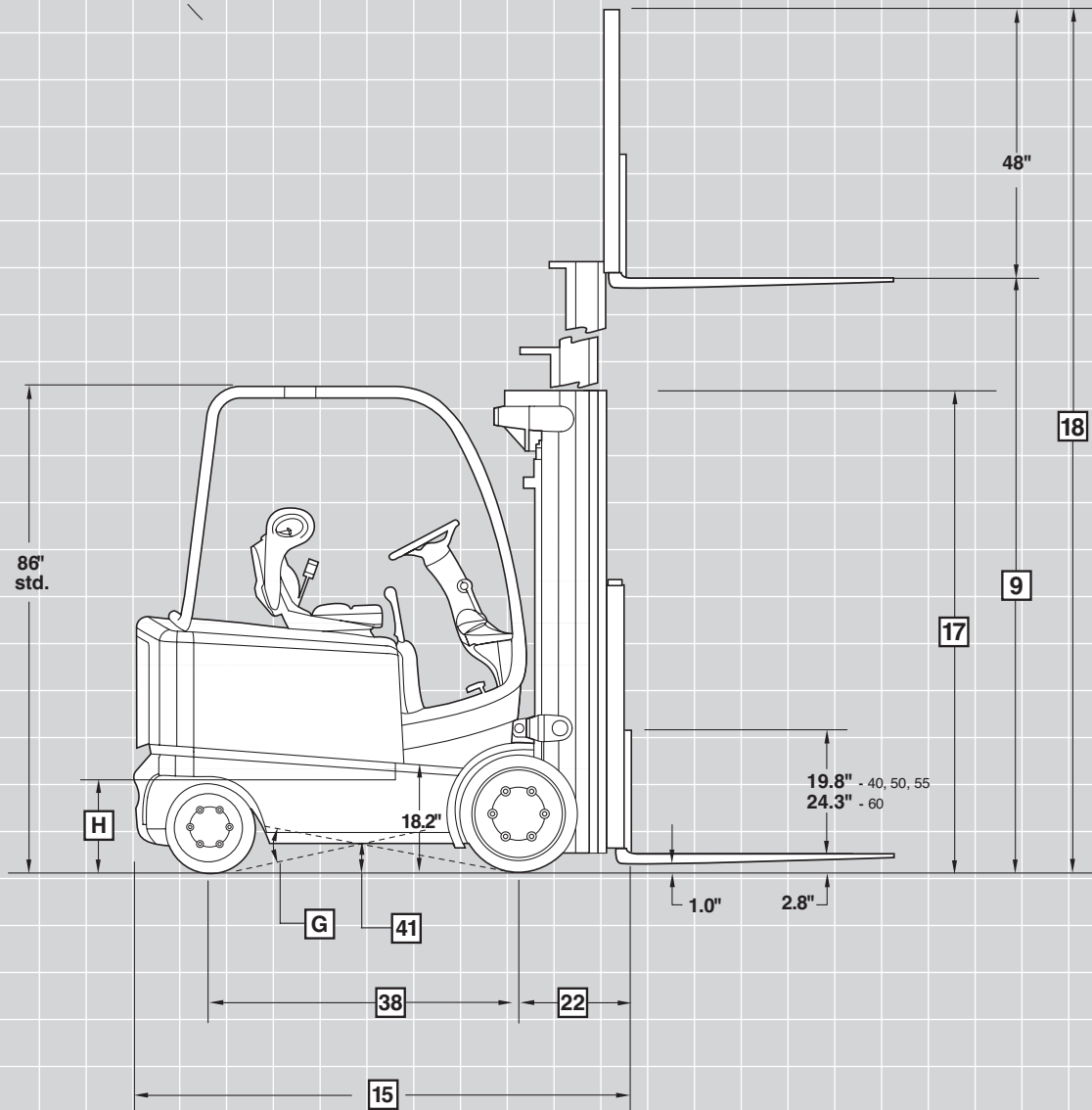

|                     |                                       |   |                               | Crown Equipment Corporation |                |                       |  |
|---------------------|---------------------------------------|---|-------------------------------|-----------------------------|----------------|-----------------------|--|
| General Information | 1                                     | <b>Manufacturer</b>                         |                               | Crown Equipment Corporation |                |                       |  |
|                     | 2                                     | <b>Model</b>                                |                               | FC 4010-40                  | FC 4020-40     |                       |  |
|                     | 3                                     | <b>Load Capacity*</b>                       | lb                            | 4000                        |                |                       |  |
|                     | 4                                     | <b>Load Center</b>                          | Fork Face to Load CG          | in                          | 24             |                       |  |
|                     | 5                                     | <b>Power</b>                                | Electric                      | 36-Volt / 48-Volt           |                |                       |  |
|                     | 6                                     | <b>Operator Type</b>                        | Sitdown Rider Counterbalanced |                             |                |                       |  |
|                     | 7                                     | <b>Tire Type</b>                            | Cushion                       |                             |                |                       |  |
|                     | 8                                     | <b>Wheels (x = driven)</b>                  | Number Front/Rear             | 2x / 2                      |                |                       |  |
| Dimensions          | 9                                     | <b>Mast**</b>                               | Lifting Height (MFH)          | in                          | 188            |                       |  |
|                     |                                       |   | Free Lift Height†             | in                          | 32.2           |                       |  |
|                     | 12                                    | <b>Fork Carriage</b>                        | ITA Class II                  |                             |                |                       |  |
|                     | 13                                    | <b>Forks</b>                                | Standard L x W x T            | in                          | 36 x 4 x 1.8   |                       |  |
|                     |                                       |   | Optional Lengths              | in                          | 42, 48, 54, 60 |                       |  |
|                     | 14                                    | <b>Tilt</b>                                 | F° / B°                       | degree                      | 5 / 5          |                       |  |
|                     |                                       |   | Interlocked Fork Height††     | in                          | 66             |                       |  |
|                     |                                       | <b>Battery Compartment</b>                  |                               | in                          | 27             | 33                    |  |
|                     | 15                                    | <b>Headlength</b>                           | Length to Fork Face           | in                          | 77.8           | 84                    |  |
|                     | 16                                    | <b>Width Overall</b>                        | Standard Tread                | in                          | 43.4           |                       |  |
|                     |                                       |   | Wide Tread                    | in                          | 47.5           |                       |  |
|                     | 17                                    | <b>Height</b>                               | Mast Collapsed                | in                          | 83             |                       |  |
|                     |                                       |   | Mast Extended†                | in                          | 236            |                       |  |
|                     | 21                                    | <b>Turning Radius</b>                       |                               | in                          | 69.1           | 75.3                  |  |
| 22                  | <b>Load Distance</b>                  | Center of Wheel to Fork Face                | in                            | 15.8                        |                |                       |  |
| 23                  | <b>Aisle Width (Add Load + Clear)</b> | Right Angle Stack                           | in                            | 84.9                        | 91.1           |                       |  |
| Performance         | 24                                    | <b>Speed Travel</b>                         | Empty / Loaded                | 48V mph                     | 11 / 10.2      |                       |  |
|                     |                                       |   | Empty / Loaded                | 36V mph                     | 8.9 / 8.3      |                       |  |
|                     | 25                                    | <b>Speed Lift</b>                           | Empty / Loaded                | 48V fpm                     | 100 / 75       |                       |  |
|                     |                                       |   | Empty / Loaded                | 36V fpm                     | 76 / 53        |                       |  |
| 26                  | <b>Speed Lower</b>                    | Empty / Loaded                              | fpm                           | 84                          |                |                       |  |
| Weights             | 32                                    | <b>Weight, Less Battery</b>                 |                               | lb                          | 7,243          | 7,195                 |  |
|                     | 33                                    | <b>Axle Load with Max Battery, Loaded</b>   | Front                         | lb                          | 11,987         | 11,752                |  |
|                     |                                       |   | Rear                          | lb                          | 1,886          | 2,242                 |  |
|                     | 34                                    | <b>Axle Load with Max Battery, Unloaded</b> | Front                         | lb                          | 4,787          | 4,851                 |  |
| Rear                |                                       |   | lb                            | 5,086                       | 5,144          |                       |  |
| Chassis             | 36                                    | <b>Tires</b>                                | Size Front                    | in                          | 21 x 7 x 15    |                       |  |
|                     | 37                                    |   | Size Rear                     | in                          | 16 x 6 x 10.5  |                       |  |
|                     | 38                                    | <b>Wheelbase</b>                            |                               | in                          | 49.7           | 54.7                  |  |
|                     | 39                                    | <b>Tread/Track Width</b>                    | Front Standard / Rear         | in                          | 36.4 / 36      |                       |  |
|                     |                                       |   | Front Optional / Rear         | in                          | 40.5 / 36      |                       |  |
|                     | 40                                    | <b>Ground Clearance, Loaded</b>             | Lowest Point                  | in                          | 3              |                       |  |
|                     | 41                                    |   | Center of Wheelbase           | in                          | 4.8            |                       |  |
|                     | G                                     | <b>Grade Clearance, Loaded</b>              |                               | %                           | 38             | 35                    |  |
|                     | 42                                    | <b>Brakes</b>                               | Service                       | Foot-Hydraulic              |                |                       |  |
|                     |                                       |   | Parking                       | Hand-Hydraulic              |                |                       |  |
| Battery             | 44                                    | <b>Battery</b>                              | Type                          | Lead-Acid                   |                |                       |  |
|                     | 46                                    |   | Weight Min/Max                | 2630 / 3200                 | 2800 / 4000    |                       |  |
|                     |                                       |   | Size Max†††                   | 27.25 x 38.69 x 22.75       |                | 32.94 x 38.69 x 22.75 |  |
|                     |                                       |   | Battery Volts Amp/Hours       | 36V                         | 1210           | 1430                  |  |
|                     |                                       |   | Max Capacity (6 hr)           | 48V                         | 880            | 1100                  |  |
| H                   | <b>Battery Floor Height</b>           | With Rollers / w/o Rollers                  | in                            | 17.4 / 17.1                 |                |                       |  |
| Motors              | 47                                    | <b>Motors</b>                               | Tractor Motor, dia            | in                          | 11.4           |                       |  |
|                     | 48                                    |   | Lift Motor, dia               | in                          | 7.2            |                       |  |
|                     | 57                                    | <b>Operating Pressure</b>                   | For Attachments               | psi                         | Up to 3000     |                       |  |

\* Optional masts, attachments, longer load dimensions, and higher lifting heights may result in derating of the capacity. Contact dealer.

\*\* Other mast heights available. See chart for other standard mast heights.

† Includes load backrest.

†† Forward tilt restricted to 2° above this height.

††† With maintenance free batteries or batteries with a lid (flat top) consult factory.

|                     |                                       |   | Crown Equipment Corporation   |                       |                       |             |        |
|---------------------|---------------------------------------|---|-------------------------------|-----------------------|-----------------------|-------------|--------|
|                     |                                       |   | FC 4010-50                    | FC 4020-50            | FC 4040-50            |             |        |
| General Information | 1                                     | <b>Manufacturer</b>                         | Crown Equipment Corporation   |                       |                       |             |        |
|                     | 2                                     | <b>Model</b>                                | FC 4010-50                    | FC 4020-50            | FC 4040-50            |             |        |
|                     | 3                                     | <b>Load Capacity*</b>                       | lb                            | 5000                  |                       |             |        |
|                     | 4                                     | <b>Load Center</b>                          | Fork Face to Load CG          | in                    | 24                    |             |        |
|                     | 5                                     | <b>Power</b>                                | Electric                      | 36-Volt / 48-Volt     |                       |             |        |
|                     | 6                                     | <b>Operator Type</b>                        | Sitdown Rider Counterbalanced |                       |                       |             |        |
|                     | 7                                     | <b>Tire Type</b>                            | Cushion                       |                       |                       |             |        |
|                     | 8                                     | <b>Wheels (x = driven)</b>                  | Number Front/Rear             | 2x / 2                |                       |             |        |
| Dimensions          | 9                                     | <b>Mast**</b>                               | Lifting Height (MFH)          | in                    | 188                   |             |        |
|                     |                                       |   | Free Lift Height†             | in                    | 32.2                  |             |        |
|                     | 12                                    | <b>Fork Carriage</b>                        | ITA Class II                  |                       |                       |             |        |
|                     | 13                                    | <b>Forks</b>                                | Standard L x W x T            | in                    | 36 x 4 x 1.8          |             |        |
|                     |                                       |   | Optional Lengths              | in                    | 42, 48, 54, 60        |             |        |
|                     | 14                                    | <b>Tilt</b>                                 | F° / B°                       | degree                | 5 / 5                 |             |        |
|                     |                                       |   | Interlocked Fork Height††     | in                    | 66                    |             |        |
|                     |                                       | <b>Battery Compartment</b>                  |                               | in                    | 27                    | 33          | 36     |
|                     | 15                                    | <b>Headlength</b>                           | Length to Fork Face           | in                    | 81.2                  | 84          | 87.1   |
|                     | 16                                    | <b>Width Overall</b>                        | Standard Tread                | in                    | 43.4                  |             |        |
|                     |                                       |   | Wide Tread                    | in                    | 47.5                  |             |        |
|                     | 17                                    | <b>Height</b>                               | Mast Collapsed                | in                    | 83                    |             |        |
|                     |                                       |   | Mast Extended†                | in                    | 236                   |             |        |
|                     | 21                                    | <b>Turning Radius</b>                       |                               | in                    | 71.9                  | 75.4        | 78.0   |
| 22                  | <b>Load Distance</b>                  | Center of Wheel to Fork Face                | in                            | 15.8                  |                       |             |        |
| 23                  | <b>Aisle Width (Add Load + Clear)</b> | Right Angle Stack                           | in                            | 87.7                  | 91.2                  | 93.8        |        |
| Performance         | 24                                    | <b>Speed Travel</b>                         | Empty / Loaded                | 48V                   | mph                   | 10.9 / 9.9  |        |
|                     |                                       |   | Empty / Loaded                | 36V                   | mph                   | 8.8 / 8.0   |        |
|                     | 25                                    | <b>Speed Lift</b>                           | Empty / Loaded                | 48V                   | fpm                   | 100 / 70    |        |
|                     |                                       |   | Empty / Loaded                | 36V                   | fpm                   | 76 / 49     |        |
| 26                  | <b>Speed Lower</b>                    | Empty / Loaded                              | fpm                           | 84                    |                       |             |        |
| Weights             | 32                                    | <b>Weight, Less Battery</b>                 |                               | lb                    | 8,090                 | 7,736       | 7,454  |
|                     | 33                                    | <b>Axle Load with Max Battery, Loaded</b>   | Front                         | lb                    | 13,616                | 13,641      | 13,456 |
|                     |                                       |   | Rear                          | lb                    | 2,103                 | 1,895       | 2,097  |
|                     | 34                                    | <b>Axle Load with Max Battery, Unloaded</b> | Front                         | lb                    | 4,616                 | 5,014       | 4,829  |
| Rear                |                                       |   | lb                            | 6,104                 | 5,522                 | 5,724       |        |
| Chassis             | 36                                    | <b>Tires</b>                                | Size Front                    | in                    | 21 x 8 x 15           |             |        |
|                     | Size Rear                             |   | in                            | 16 x 6 x 10.5         |                       |             |        |
|                     | 38                                    | <b>Wheelbase</b>                            | in                            | 49.7                  | 54.7                  | 54.7        |        |
|                     | 39                                    | <b>Tread/Track Width</b>                    | Front Standard / Rear         | in                    | 35.4 / 36             |             |        |
|                     |                                       |   | Front Optional / Rear         | in                    | 39.5 / 36             |             |        |
|                     | 40                                    | <b>Ground Clearance, Loaded</b>             | Lowest Point                  | in                    | 3                     |             |        |
|                     | Center of Wheelbase                   |   | in                            | 4.8                   |                       |             |        |
|                     | G                                     | <b>Grade Clearance, Loaded</b>              | %                             | 38                    | 35                    | 35          |        |
| 42                  | <b>Brakes</b>                         | Service                                     | Foot-Hydraulic                |                       |                       |             |        |
|                     |                                       | Parking                                     | Hand-Hydraulic                |                       |                       |             |        |
| Battery             | 44                                    | <b>Battery</b>                              | Type                          | Lead-Acid             |                       |             |        |
|                     |                                       |   | Weight Min/Max                | 2630 / 3200           | 2800 / 4000           | 3100 / 4250 |        |
|                     |                                       | Size Max†††                                 | 27.25 x 38.69 x 22.75         | 32.94 x 38.69 x 22.75 | 36.38 x 38.69 x 22.75 |             |        |
|                     |                                       | Battery Volts Amp/Hours                     | 36V                           | 1210                  | 1430                  | 1540        |        |
|                     |                                       | Max Capacity (6 hr)                         | 48V                           | 880                   | 1100                  | 1210        |        |
| H                   | <b>Battery Floor Height</b>           | With Rollers / w/o Rollers                  | in                            | 17.4 / 17.1           |                       |             |        |
| Motors              | 47                                    | <b>Motors</b>                               | Tractor Motor, dia            | in                    | 11.4                  |             |        |
|                     | 48                                    |   | Lift Motor, dia               | in                    | 7.2                   |             |        |
|                     | 57                                    | <b>Operating Pressure</b>                   | For Attachments               | psi                   | Up to 3000            |             |        |

\* Optional masts, attachments, longer load dimensions, and higher lifting heights may result in derating of the capacity. Contact dealer.

\*\* Other mast heights available. See chart for other standard mast heights.

† Includes load backrest.

†† Forward tilt restricted to 2° above this height.

††† With maintenance free batteries or batteries with a lid (flat top) consult factory.

|                     |                      |                                      |                              | Crown Equipment Corporation   |                       |             |  |
|---------------------|----------------------|--------------------------------------|------------------------------|-------------------------------|-----------------------|-------------|--|
|                     |                      |                                      |                              | FC 4020-55                    | FC 4040-55            |             |  |
| General Information | 1                    | Manufacturer                         |                              | Crown Equipment Corporation   |                       |             |  |
|                     | 2                    | Model                                |                              | FC 4020-55                    | FC 4040-55            |             |  |
|                     | 3                    | Load Capacity*                       | lb                           | 5500                          |                       |             |  |
|                     | 4                    | Load Center                          | Fork Face to Load CG         | in                            | 24                    |             |  |
|                     | 5                    | Power                                | Electric                     | 36-Volt / 48-Volt             |                       |             |  |
|                     | 6                    | Operator Type                        |                              | Sitdown Rider Counterbalanced |                       |             |  |
|                     | 7                    | Tire Type                            |                              | Cushion                       |                       |             |  |
|                     | 8                    | Wheels (x = driven)                  | Number Front/Rear            | 2x / 2                        |                       |             |  |
| Dimensions          | 9                    | Mast**                               | Lifting Height (MFH)         | in                            | 188                   |             |  |
|                     |                      |                                      | Free Lift Height†            | in                            | 32.2                  |             |  |
|                     | 12                   | Fork Carriage                        |                              | ITA Class II                  |                       |             |  |
|                     | 13                   | Forks                                | Standard L x W x T           | in                            | 36 x 5 x 1.8          |             |  |
|                     |                      |                                      | Optional Lengths             | in                            | 42, 48, 54, 60        |             |  |
|                     | 14                   | Tilt                                 | F° / B°                      | degree                        | 5 / 5                 |             |  |
|                     |                      |                                      | Interlocked Fork Height††    | in                            | 66                    |             |  |
|                     |                      | Battery Compartment                  |                              | in                            | 33                    | 36          |  |
|                     | 15                   | Headlength                           | Length to Fork Face          | in                            | 87.4                  | 90.5        |  |
|                     | 16                   | Width Overall                        | Standard Tread               | in                            | 45.2                  |             |  |
|                     |                      |                                      | Wide Tread                   | in                            | 48                    |             |  |
|                     | 17                   | Height                               | Mast Collapsed               | in                            | 83                    |             |  |
|                     | 18                   |                                      | Mast Extended†               | in                            | 236                   |             |  |
|                     | 21                   | Turning Radius                       |                              | in                            | 78.2                  | 80.9        |  |
|                     | 22                   | Load Distance                        | Center of Wheel to Fork Face | in                            | 15.8                  |             |  |
|                     | 23                   | Aisle Width (Add Load + Clear)       | Right Angle Stack            | in                            | 94.0                  | 96.7        |  |
|                     | Performance          | 24                                   | Speed Travel                 | Empty / Loaded                | 48V mph               | 10.8 / 9.7  |  |
|                     |                      |                                      |                              | Empty / Loaded                | 36V mph               | 8.8 / 7.8   |  |
| 25                  |                      | Speed Lift                           | Empty / Loaded               | 48V fpm                       | 100 / 68              |             |  |
|                     |                      |                                      | Empty / Loaded               | 36V fpm                       | 76 / 47               |             |  |
| 26                  | Speed Lower          | Empty / Loaded                       | fpm                          | 84                            |                       |             |  |
| Weights             | 32                   | Weight, Less Battery                 |                              | lb                            | 8,285                 | 8,166       |  |
|                     | 33                   | Axle Load with Max Battery, Loaded   | Front                        | lb                            | 14,308                | 14,111      |  |
|                     |                      |                                      | Rear                         | lb                            | 2,277                 | 2,655       |  |
|                     | 34                   | Axle Load with Max Battery, Unloaded | Front                        | lb                            | 4,818                 | 4,622       |  |
| Rear                |                      |                                      | lb                           | 6,267                         | 6,644                 |             |  |
| Chassis             | 36                   | Tires                                | Size Front                   | in                            | 21 x 9 x 15           |             |  |
|                     |                      |                                      | Size Rear                    | in                            | 16 x 7 x 10.5         |             |  |
|                     | 38                   | Wheelbase                            |                              | in                            | 54.7                  | 54.7        |  |
|                     | 39                   | Tread/Track Width                    | Front Standard / Rear        | in                            | 36.2 / 36             |             |  |
|                     |                      |                                      | Front Optional / Rear        | in                            | 39 / 36               |             |  |
|                     | 40                   | Ground Clearance, Loaded             | Lowest Point                 | in                            | 3                     |             |  |
|                     | 41                   | Grade Clearance, Loaded              | Center of Wheelbase          | in                            | 4.8                   |             |  |
|                     | G                    |                                      |                              | %                             | 35                    | 35          |  |
| 42                  | Brakes               | Service                              | Foot-Hydraulic               |                               |                       |             |  |
| 43                  |                      | Parking                              | Hand-Hydraulic               |                               |                       |             |  |
| Battery             | 44                   | Battery                              | Type                         | Lead-Acid                     |                       |             |  |
|                     |                      |                                      | Weight Min/Max               | 2800 / 4000                   |                       | 3100 / 4250 |  |
|                     |                      | Size Max†††                          | 32.94 x 38.69 x 22.75        |                               | 36.38 x 38.69 x 22.75 |             |  |
|                     |                      | Battery Volts Amp/Hours              | 36V                          | 1430                          | 1540                  |             |  |
|                     |                      | Max Capacity (6 hr)                  | 48V                          | 1100                          | 1210                  |             |  |
| H                   | Battery Floor Height | With Rollers / w/o Rollers           | in                           | 17.4 / 17.1                   |                       |             |  |
| Motors              | 47                   | Motors                               | Tractor Motor, dia           | in                            | 11.4                  |             |  |
|                     | 48                   |                                      | Lift Motor, dia              | in                            | 7.2                   |             |  |
|                     | 57                   | Operating Pressure                   | For Attachments              | psi                           | Up to 3000            |             |  |

\* Optional masts, attachments, longer load dimensions, and higher lifting heights may result in derating of the capacity. Contact dealer.

\*\* Other mast heights available. See chart for other standard mast heights.

† Includes load backrest.

†† Forward tilt restricted to 2° above this height.

††† With maintenance free batteries or batteries with a lid (flat top) consult factory.

|                     |                                       |   |                               | Crown Equipment Corporation |                |                       |
|---------------------|---------------------------------------|---|-------------------------------|-----------------------------|----------------|-----------------------|
|                     |                                       |   |                               | FC 4020-60                  | FC 4040-60     |                       |
| General Information | 1                                     | <b>Manufacturer</b>                         |                               | Crown Equipment Corporation |                |                       |
|                     | 2                                     | <b>Model</b>                                |                               | FC 4020-60                  | FC 4040-60     |                       |
|                     | 3                                     | <b>Load Capacity*</b>                       | lb                            | 6000                        |                |                       |
|                     | 4                                     | <b>Load Center</b>                          | Fork Face to Load CG          | in                          | 24             |                       |
|                     | 5                                     | <b>Power</b>                                | Electric                      | 36-Volt / 48-Volt           |                |                       |
|                     | 6                                     | <b>Operator Type</b>                        | Sitdown Rider Counterbalanced |                             |                |                       |
|                     | 7                                     | <b>Tire Type</b>                            | Cushion                       |                             |                |                       |
|                     | 8                                     | <b>Wheels (x = driven)</b>                  | Number Front/Rear             | 2x / 2                      |                |                       |
| Dimensions          | 9                                     | <b>Mast**</b>                               | Lifting Height (MFH)          | in                          | 180            |                       |
|                     |                                       |   | Free Lift Height†             | in                          | 32.2           |                       |
|                     | 12                                    | <b>Fork Carriage</b>                        | ITA Class III                 |                             |                |                       |
|                     | 13                                    | <b>Forks</b>                                | Standard L x W x T            | in                          | 36 x 5 x 1.8   |                       |
|                     |                                       |   | Optional Lengths              | in                          | 42, 48, 54, 60 |                       |
|                     | 14                                    | <b>Tilt</b>                                 | F° / B°                       | degree                      | 5 / 5          |                       |
|                     |                                       |   | Interlocked Fork Height††     | in                          | 66             |                       |
|                     |                                       | <b>Battery Compartment</b>                  |                               | in                          | 33             | 36                    |
|                     | 15                                    | <b>Headlength</b>                           | Length to Fork Face           | in                          | 87.7           | 90.8                  |
|                     | 16                                    | <b>Width Overall</b>                        | Standard Tread                | in                          | 45             |                       |
|                     |                                       |   | Wide Tread                    | in                          | 48             |                       |
|                     | 17                                    | <b>Height</b>                               | Mast Collapsed                | in                          | 83             |                       |
|                     |                                       |   | Mast Extended†                | in                          | 228            |                       |
|                     | 21                                    | <b>Turning Radius</b>                       |                               | in                          | 78.2           | 80.9                  |
| 22                  | <b>Load Distance</b>                  | Center of Wheel to Fork Face                | in                            | 16.1                        |                |                       |
| 23                  | <b>Aisle Width (Add Load + Clear)</b> | Right Angle Stack                           | in                            | 94.3                        | 97.0           |                       |
| Performance         | 24                                    | <b>Speed Travel</b>                         | Empty / Loaded                | 48V                         | mph            | 10.8 / 9.5            |
|                     |                                       |   | Empty / Loaded                | 36V                         | mph            | 8.8 / 7.6             |
|                     | 25                                    | <b>Speed Lift</b>                           | Empty / Loaded                | 48V                         | fpm            | 100 / 66              |
|                     |                                       |   | Empty / Loaded                | 36V                         | fpm            | 76 / 45               |
| 26                  | <b>Speed Lower</b>                    | Empty / Loaded                              | fpm                           | 84                          |                |                       |
| Weights             | 32                                    | <b>Weight, Less Battery</b>                 |                               | lb                          | 8,687          | 8,226                 |
|                     | 33                                    | <b>Axle Load with Max Battery, Loaded</b>   | Front                         | lb                          | 15,364         | 15,078                |
|                     |                                       |   | Rear                          | lb                          | 2,124          | 2,248                 |
|                     | 34                                    | <b>Axle Load with Max Battery, Unloaded</b> | Front                         | lb                          | 4,984          | 4,699                 |
| Rear                |                                       |   | lb                            | 6,503                       | 6,627          |                       |
| Chassis             | 36                                    | <b>Tires</b>                                | Size Front                    | in                          | 21 x 9 x 15    |                       |
|                     | 37                                    |   | Size Rear                     | in                          | 16 x 7 x 10.5  |                       |
|                     | 38                                    | <b>Wheelbase</b>                            |                               | in                          | 54.7           | 54.7                  |
|                     | 39                                    | <b>Tread/Track Width</b>                    | Front Standard / Rear         | in                          | 36.2 / 36      |                       |
|                     |                                       |   | Front Optional / Rear         | in                          | 39 / 36        |                       |
|                     | 40                                    | <b>Ground Clearance, Loaded</b>             | Lowest Point                  | in                          | 3              |                       |
|                     | 41                                    |   | Center of Wheelbase           | in                          | 4.8            |                       |
|                     | G                                     | <b>Grade Clearance, Loaded</b>              |                               | %                           | 35             | 35                    |
| 42                  | <b>Brakes</b>                         | Service                                     | Foot-Hydraulic                |                             |                |                       |
|                     |                                       | Parking                                     | Hand-Hydraulic                |                             |                |                       |
| Battery             | 44                                    | <b>Battery</b>                              | Type                          | Lead-Acid                   |                |                       |
|                     |                                       |   | Weight Min/Max                | 2800 / 4000                 |                | 3100 / 4250           |
|                     |                                       |   | Size Max†††                   | 32.94 x 38.69 x 22.75       |                | 36.38 x 38.69 x 22.75 |
|                     |                                       |   | Battery Volts Amp/Hours       | 36V                         | 1430           | 1540                  |
|                     |                                       |   | Max Capacity (6 hr)           | 48V                         | 1100           | 1210                  |
| H                   | <b>Battery Floor Height</b>           | With Rollers / w/o Rollers                  | in                            | 17.4 / 17.1                 |                |                       |
| Motors              | 47                                    | <b>Motors</b>                               | Tractor Motor, dia            | in                          | 11.4           |                       |
|                     | 48                                    |   | Lift Motor, dia               | in                          | 7.2            |                       |
|                     | 57                                    | <b>Operating Pressure</b>                   | For Attachments               | psi                         | Up to 3000     |                       |

\* Optional masts, attachments, longer load dimensions, and higher lifting heights may result in derating of the capacity. Contact dealer.

\*\* Other mast heights available. See chart for other standard mast heights.

† Includes load backrest.

†† Forward tilt restricted to 2° above this height.

††† With maintenance free batteries or batteries with a lid (flat top) consult factory.

## FC 4000 Series

## Specifications

| Mast Chart<br>40, 50 and 55FC |                     |    | TL  |     |     | TT   |      |      |      |      |      |      | QUAD |      |      |      |      |      |
|-------------------------------|---------------------|----|-----|-----|-----|------|------|------|------|------|------|------|------|------|------|------|------|------|
| 9                             | Lifting Height      | in | 126 | 138 | 150 | 188  | 206* | 216* | 231* | 246* | 258* | 276  | 291  | 240* | 258* | 276* | 294* | 312* |
| 11                            | Free Lift Height†   | in | 5.6 | 5.6 | 5.6 | 32.2 | 38.2 | 44.2 | 50.2 | 56.2 | 62.2 | 68.2 | 74.2 | 31.8 | 39.8 | 43.8 | 49.8 | 55.8 |
| 14                            | Interlocked Fork Ht | in | 78  | 78  | 78  | 66   | 72   | 78   | 84   | 90   | 96   | 102  | 108  | 68   | 74   | 80   | 86   | 92   |
| 17                            | Mast Collapsed Ht   | in | 83  | 89  | 95  | 83   | 89   | 95   | 101  | 107  | 113  | 119  | 125  | 83   | 89   | 95   | 101  | 107  |
| 18                            | Mast Extended Ht†   | in | 174 | 186 | 198 | 236  | 254  | 264  | 279  | 294  | 306  | 324  | 339  | 288  | 306  | 324  | 342  | 360  |

| Mast Chart<br>60FC |                     |    | TL  |     |     | TT   |      |      |      |      |      |
|--------------------|---------------------|----|-----|-----|-----|------|------|------|------|------|------|
| 9                  | Lifting Height      | in | 118 | 130 | 142 | 180  | 198* | 208* | 223* | 238* | 250* |
| 11                 | Free Lift Height†   | in | 5.9 | 5.9 | 5.9 | 32.2 | 38.2 | 44.2 | 50.2 | 56.2 | 62.2 |
| 14                 | Interlocked Fork Ht | in | 78  | 78  | 78  | 66   | 72   | 78   | 84   | 90   | 96   |
| 17                 | Mast Collapsed Ht   | in | 83  | 89  | 95  | 83   | 89   | 95   | 101  | 107  | 113  |
| 18                 | Mast Extended Ht†   | in | 166 | 178 | 190 | 228  | 246  | 256  | 271  | 286  | 298  |

\*Wide tread drive axle may be required. Refer to capacity charts.  
†Includes load backrest.

## FC 4000 Series

## Technical Information

### Standard Features

- 36/48 volt system
- Intrinsic stability system
  - Travel speed reduction when forks are above mast staging
  - Forward lift/tilt interlock
- Operator entry/exit
  - 18" step height
  - Huge entry/exit "window"
  - Tubular overhead guard upright for easy hand hold
  - Contoured battery deck lid
  - Rounded floorboard edges
  - Low, streamlined cowl
  - Compact tilt steering wheel and column
  - Large, uncluttered floorboard
- Operator compartment design features
  - Low cowl for fork and floor visibility
  - Wide placed overhead guard uprights reduce visual interference
  - Custom seat with side restraint and seat belt
  - Infinite adjustment steering wheel column
  - Fingertip applied/released parking brake with tone alert
  - Urethane covered control handles with tactile feedback
  - Natural position for forward/reverse selector
  - Rubber floor mat/rubber covered pedals
- Exclusive power disc brake with regenerative motor plugging
- Crown-manufactured drive and lift motors
- High visibility mast with in-line hose routing

- Crown drive system with GE EV-100 ZX SCR
- Hour meter/battery discharge indicator/fault memory
- Lift out or side removal battery access
- Battery side retainer with interlock and fault identification
- Crown's InfoPoint™ Feature
- No tool lift out floorboards
- Three-spool valve
- O-ring face seal hydraulic fittings
- Overhead guard
- 48" high load backrest
- 350 amp battery connector
- Color-coded wiring
- Battery disconnect handle

### Optional Equipment

- Enhanced display with LED diagnostics
- Sideshifter
- Lift interrupt
- Freezer package
- Corrosion conditioning
- UL "EE" rating
- TL and quad mast styles
- Polished and tapered forks
- Fork lengths
- Hydraulic valves for attachments
- SCR pump control for lift and accessory hydraulics
- Quick disconnect connectors
- Attachment pressure regulator and gauge
- Special tilt
- Brush wear and motor over temperature indicators for all motors
- Suspension seat
- Seat armrest
- Keyless on/off switch
- Mirrors

- Work lights
- Storage tray with clipboard support
- Anti-cinch seat belts
- Operator fan
- Back-up brake and tail light
- Strobe lights
- Audible travel alarm
- Fire extinguisher
- Tow pin
- Automatic parking brake, (seat activated)
- Brake activated traction cutout
- Foot operated directional control
- Full battery side doors
- Battery compartment rollers
- Electronic compartment fan
- Universal accessory clamp
- Universal pad clip and hook
- Universal terminal mounting plate
- Pos/Neg accessory cable
- Wide tread widths
- Load backrest heights
- Drive-in rack overhead guard
- Non-marking smooth or lug rubber tires

### Batteries

Battery deck lid releases easily to expose battery for lift out or side battery removal. Optional battery rollers for use with mechanized extraction equipment. A low battery side retainer is standard. Full battery side doors are optional.

### Driveability

The FC 4000 benefits from Crown's design and engineering excellence. Numerous features improve operator comfort and productivity.

A low 18" step height first greets the operator. A low, streamlined

battery cover helps the operator glide into the truck's seat. The overhead guard is shaped to open up the entry/exit window and its tubular design provides a comfortable hand grip location for a variety of operator heights. The compact tilt steer column and steer wheel further facilitate entry/exit. Tilt column is spring loaded to easily move up and away. Floorboard (625-sq in) is uncluttered and rubber covered to insulate the operator from vibration. Sculpted floorboard design promotes visibility to the drive tires which can reduce product and pallet damage. Brake pedal effort is reduced. Pedal to pedal and floor to pedal relationships are refined for comfort.

Better visibility can be seen everywhere you look. A low cowl for fork and carriage visibility, a high visibility mast, a compact steer column, a sculpted floorboard and a "waterfall" overhead guard all contribute to superior visibility.

Control handles are crafted into the compartment and "fanned" for easy selection. They are urethane covered with tactile feedback for comfort and easy selection. Control actuation forces are minimal and responsive.

Finger applied/released parking brake with tone alert enhances operator entry/exit and naturally encourages its use. Battery disconnect is easy to reach and operate. Easy to actuate rocker-type switches are conveniently located to select optional work lights or fan. A large convex horn button is housed in the center of the wheel.

### Hydraulics

Premium hydraulic function control valve provides precise metering of lift, tilt and accessory functions. Compensating section in the valve provides repeatable function speed regardless of load condition. Hydraulic lever actuation is minimal, reducing stress. Compensating section also improves overall system efficiency.

Tilt compensator prevents tilt from lunging or speeding up when doing simultaneous functions.

Crown lift/tilt interlock system provides extended forward tilt at low fork heights, reduced forward tilt at elevated heights to improve truck stability when forks are elevated.

The control valves modular design allows easy addition of accessory functions. Maximum lowering speed is limited by pressure compensating flow control valve and velocity fuses. Integrated hydraulic cylinder cushions soften mast staging. All lift cylinder rams are plated and retract into the hydraulic oil for additional corrosion protection when forks are lowered.

The steel oil reservoir is integral to the frame which helps to dissipate hydraulic oil heat. This clean, leak-free design includes suction strainer with separate, easily accessible fill port and dipstick with filtered breathers. Oil is returned through a replaceable spin-on type oil filter.

### Crown Drive System

Time proven and field accepted heavy-duty high amp rated GE EV-100 ZX SCR system. 36- or 48-volt electrical power system. Control system is standard on traction, optional on pump motor. Total microprocessor control with on-board drivers and diagnostic capabilities. Standard regenerative plugging feature for increased motor brush life and reduced motor heating during direction reversals. Traction control features standard bypass (1-A) and field weakening for increased travel speed and reduced heat to controllers. Includes hour meter for SCR controlled motors.

Optional SCR pump control allows smoother operating lift system with decreased brush wear and extended motor life. Accessory function pump speeds can be fine-tuned by adjusting pump motor RPMs to further reduce energy consumption and improve overall system efficiency.

Standard and enhanced display panel available:

- Standard display has an easy-to-read battery discharge indicator (fuel gauge).
- Optional enhanced display and navigation buttons make troubleshooting quick. Service personnel with no additional terminal can retrieve fault history. Register remembers the last 16 event codes that have occurred in the SCR-controlled systems.
- Crown's InfoPoint™ Feature provides clear visual communication for service technician. Practical color component maps (main map under seat deck, two labels for SCR panel and contactor panel, one in left step for distribution panel) enable service technician to easily locate components. Includes Quick Reference Guide that describes event codes and procedures. Component markings for easy verification.
- SRO (static return to off) safety feature requires the operator to set the direction selector and accelerator to neutral, and then select a direction each time the operator gets back on the seat.
- The hour meter readings for seat are displayed whenever the key switch is turned off. Hour meter for lift is included when equipped with optional SCR hydraulics.

Accelerator control for traction is a solid state device for long life and reliability. Extensive use of reliable plug-in connectors contributes to ease of truck serviceability and the durability of wiring harnesses. Provisions for add-on options have been made. Optional work lights are shock mounted within protective guard for longevity and durability.

### Crown Manufactured Mast Assembly

Large, rugged mast trunnion mount on drive axle and extra heavy tilt cylinders with self-aligning bushings secure mast.

High visibility mast features nested-rail design with lift cylinders positioned behind the rails. Heavy-duty mast is engineered to provide smooth reliable operation. Large hydraulic hose reeves and hose placement are engineered to reduce hose wear and increase hose life. Hose routing places hoses in-line versus side-by-side to reduce visual interference. Large lift chains are used for long reliable service life. Large diameter lift cylinders provide smooth operation.

Class II and III fork carriages are available. Optional TL and quad mast is available.

### Crown Engineered Drive Train

Drive motor is transverse-mounted high above the floor away from dirt and moisture and provides easy access for brush inspection and overall motor serviceability. Heavy-duty triple reduction, all gear design operates in oil bath. Engineered for durability with reduced vibration and noise.

### Steering

Fully hydrostatic system with equal-area, double-acting cylinder provides equally responsive steering rate both ways (4.8 turns lock to lock). Rugged cast axle frame; forged spindle and connecting links eliminate the need for adjustment. One-piece forged spindle and kingpin in tapered roller bearings for improved life and serviceability. Spherical bearings with tapered pins in connecting links eliminate any play in linkage. All bearing locations are sealed to exclude contaminants and are equipped with lubrication fittings for ease of service. Axle articulates in rubber isolation bushing to improve truck handling and ride.

### Power Disc-Braking System

Service brakes are located in the wheel ends with a unique full circle power disc design. Hydraulic power is utilized to actuate a full circle rotor. This design reduces operator pedal effort and improves brake response. Brake service life will increase due to a large full circle friction pad. Access

to the friction pads for inspection or replacement is direct and easy, reducing downtime for brake maintenance. Parking brake is push button located on the cowl to the right of the steer wheel column. Tone alert reminder is standard. Parking brake is located on the end of the motor shaft to take advantage of gear reduction. Optional seat activated automatic parking brake is available.

### Crown Manufactured Motors

Largest in its class, 11.4" diameter traction motor is ventilated and fan-cooled; its large diameter and fan provide for improved thermal performance. Ventilated, fan-cooled pump motor for lift and accessory functions is mounted on a central bracket and is enclosed in a protective compartment. Totally enclosed, fan-cooled power steering motor is also sub-plate mounted for easy brush access and removal.

### Optional Suspension Seat – Special Conditions

For applications involving repeated impact loading (dockboards, expansion joints, etc.) or applications involving driving over rough surfaces (parking lots, etc.) the dampened suspension seat is recommended in order to provide an improved ride for the operator.

### Other Options

1. Audible Travel Alarm.
2. Flashing Lights. Safety considerations and dangers associated with audible travel alarms and flashing lights include:

- Multiple alarms and/or lights can cause confusion.
- Workers ignore the alarms and/or lights after day-in and day-out exposure.
- Operator may transfer the responsibility for "looking out" to the pedestrians.
- Annoys operators and pedestrians.

### Other Options Available

Contact your Crown dealer.

*Dimensions and performance data given may vary due to manufacturing tolerances. Performance is based on an average size vehicle and is affected by weight, condition of truck, how it is equipped and the conditions of the operating area. Crown products and specifications are subject to change without notice.*